

# SERVICE INTEGRATION BETWEEN WIRELESS SYSTEMS: *A core-level approach to internetworking*

Paulo Pinto, Luis Bernardo

*Faculdade de Ciências e Tecnologia, Universidade Nova de Lisboa, P-2829-516 Caparica, Portugal*

*Email: [pfp@uninova.pt](mailto:pfp@uninova.pt), [lflb@uninova.pt](mailto:lflb@uninova.pt)*

Pedro Sobral

*Faculdade de Ciência e Tecnologia, Universidade Fernando Pessoa ,Porto, Portugal*

*Email: [pmsobral@ufp.pt](mailto:pmsobral@ufp.pt)*

**Keywords:** Interworking of wireless systems, wireless computing, handovers, mobility management

**Abstract:** The greater bandwidth provided by wireless LANs can be a precious asset to the wireless ubiquitous computing if the integration with 3GPP systems is done at a certain level. This paper presents a proposal to integrate wireless systems at core network level. Service integration becomes very powerful and easy. The system is not so dependent on the critical latency of vertical handovers and the users feel a unique system providing services. Little changes are required to the current 3GPP core network. Our architecture uses the GPRS as the primary network and integrates WLANs as secondary networks, used on an availability basis. Sessions on secondary networks survive disconnection periods contributing to a seamless service provision to the user. The paper describes the overall architecture, the changes that are needed at the current 3GPP core, and the operation of the secondary networks on the aspects of data routing and security associations. Highlights about the application model are presented at the end.

## 1 INTRODUCTION

Cellular systems like Global System for Mobile Communication/General Packet Radio Service (GSM/GPRS), and its successor UMTS (Universal Mobile Telecommunication System) already provide IP-services in a ubiquitous mode. However, there are obvious limitations on bandwidth due to their coverage requirements. Wireless LANs (WLANs) have been seen as a useful add-on to provide islands of greater resources. Ways to integrate these systems are being developed and a challenge discussed in this paper is how the integration can be done to allow new services to appear (e.g. exploring mobility) and still support the existing ones.

Current proposals either envisage a complete integration of WLANs in the cellular system's architecture (*tightly coupled*) or provide integration in such a way that the systems interact poorly (*loosely coupled*). The former solution does not enlarge the type of services that can be designed from the current cellular architecture framework and the latter makes it difficult to provide a real sense of

service integration amongst the various access networks.

This paper presents a solution based on an integration performed at core network level amongst the major components (such as the SGSN – Serving GPRS Supporting Node). The system can be used in different business scenarios and not only in a 3GPP operator owned WLAN infrastructure. The paper starts with a scenario of a service to justify why a new approach to integration is viable. Our approach maintains a user session regardless of the precise Radio Access Network (RAN) used, claims that vertical handovers (between RANs) are not needed, and RAN switch can better be performed at core network level (in the UMTS sense).

Each UE (user equipment) can maintain at least one IP session over a specific RAN and can always use the session, even when it is outside the coverage area of that RAN (by using other active RANs). Services can access core-level information to: (a) improve the way they use the communication links to the UE; and (b) handle and adapt to UE mobility and connected periods (when the UE is inside the coverage of a WLAN). In order to implement our system only minor (software) modifications to the current 3G core network need to be done.

## 2 ENVISAGED SCENARIO

**Initial assumptions** – First, the reality today is that the cellular network is ubiquitous, covering 100% of the populated areas. It is very unlikely that any other radio network system will have such coverage. The consequence is that any other network will have dark areas, and supporting users in these networks alone is not feasible. Second, our UEs are equipped with two (or more) wireless interfaces working simultaneously. Third, WLANs can be owned by private organizations with agreements to the 3GPP system operators or owned by the operators themselves. Fourth, the security control provided by the USIM smart cards and global roaming agreements between 3GPP system operators form the largest operational security system in the world to date. AAA (Authentication, Authorization and Accounting) procedures between 3GPP systems and WLANs are on the verge of being approved (3GPP, 2003) and we assume them in our system.

**Download service** – Our service example extends the infostation model presented in (Frenkiel, 2000) with cellular network integration (the real subject of the example – download of data – could be part of a more sophisticated application).

A user is at home and uses the GPRS interface to start a service to download some bulk data. In his way to work, the system will try to use the WLAN RAN (near semaphores, etc.) to deliver the data. Eventually, all the data will be transferred.

In the rest of the paper, we consider GPRS as a packet service in both 2.5G and 3G systems standardized by 3GPP.

## 3 SYSTEM OVERVIEW

The capacity of radio cells will increase in the future. Cells will be smaller than the current ones. As stated in (Frodigh, 2001) we also agree that extremely high rates will not be necessary everywhere, but just in small hotspots. The question is how to integrate these hotspots?

### 3.1 Hotspot Integration

One possibility is that they are part of the cellular network as an ordinary cell. The network would predict the user movement (using the cell information) and could schedule the sending of large bulks of data when a hotspot becomes available. However, implementing such a facility at network level can be rather complex (as there is not enough

relevant information). Moreover, unless applications have knowledge of the differences in cells and adjust to specific cell data rate conditions a user might experience lack of bandwidth just because he stepped out of the coverage.

Another possibility is that high bandwidth cells are seen as special cells, not integrated in the cellular system and having a special (direct) connection to a packet data network. The user knows he is using a different interface and stepping out of coverage is easy to detect.

There are proposals for WLAN integration covering both possibilities. The *tightly coupling* option (Salkintzis, 2002) state that cells should be integrated at a low level offering an interface compatible with the 3GPP protocols. Besides the drawbacks listed above there are still the following disadvantages: (a) the WLAN must be owned by the 3GPP operator (to avoid strong exposure of core network interfaces); (b) cell displacement and configuration demands carefully engineered network planning tools and WLAN integration becomes difficult. Moreover, a great deal of control procedures are based on configuration parameters (CellID, UTRAN Registration Area (URA), Routing Area (RA), etc.) and WLAN cells have to comply with them; and (c) paging procedures and handovers (including vertical handovers) have to be defined and some technologies (e.g. IEEE 802.11) are not so optimized to make them fast enough.

The loosely coupled option (Salkintzis, 2002 and Buddhikot, 2003) assumes there is a WLAN gateway on the WLAN network (with functionalities of Foreign Agent, firewall, AAA relaying, and billing) and the connection to the 3GPP core is via GGSN (Gateway GPRS Support Node) (with a Home Agent functionality). It only makes sense to use this option with dual-mode UEs because a vertical handover to WLANs would disconnect the UE from all the functionality of the cellular networks (paging, etc.). One advantage is that high-speed traffic is never injected into the 3GPP core network. A major disadvantage is the degree of integration. WLAN networks are handled independently and will be used on an availability basis by the users, whom have to stay within the same coverage. Any service provided by the 3GPP (SMS (Short message Service), etc.) has to consider the cellular system's internet interface. Any exploitation of the UE's mobility (both in the cellular system and inside the WLAN island) is hidden by the mechanism of Mobile IP, for instance. From the applications point of view, the UE is stationary placed inside a big cloud called GPRS (or WLAN). I.e. it has a stable IP address and any mobility inside the 3GPP network is not seen from the exterior.

3GPP (3GPP, 2002) defined six scenarios of increasing levels of integration between 3GPP systems and WLANs. Scenario 3 addresses access to 3GPP PS services and includes access control and charging. (3GPP, 2003) specifies how it should be done. A loosely coupled approach was adopted but the data routing aspects are still not fully agreed (the specification covers mostly the access control and charging).

Our proposal for hotspot integration is somewhere in between the tightly and loosely options – it is at core network level. It allows the use of WLANs as a complement to the GPRS network. It is not fully incompatible with the 3GPP effort, as it will be described below.

### 3.2 Primary and Secondary Networks

In our system the GPRS network is the glue for all the other RANs. It is the primary network having all the control services (paging, etc.). All secondary networks become simpler and can have control services of their own not seen at core level (i.e. they are simply internal optimizations). Almost all of the works in internetworking assume that all these features (including paging) exist in all networks and are seen at core level. IDMP (Misra, 2001) is one of the exceptions stating that they should be customized. The most similar approach to ours was taken by MIRAI (Wu, 2002). Their primary network is a collection of BANs (Basic Access Network). Each BAN contains the usual control services, and is controlled by a CCN (Common Core Network) manager. A user selects a RAN based on a list provided by the BAN considering user location and preferences. Although, the authors consider a long list of issues to help the UE choose the RAN, some too low level or “external” reasons (e.g. battery life) can lead to unexpected choices from the applications’ point of view. CCN handles micro-

mobility (possibly inter-RAN) and participates in macro-mobility. The control features of the BAN are very similar to the ones in UMTS. It could have been implemented by the 3G system (as also stated in (Wu, 2002)) but MIRAI authors decided to implement a new radio interface.

In our system a WLAN RAN is a set of islands. Each island is formed by a set of cells and is controlled by an Island Manager (IM). Islands do not cover the entire space (i.e. there will be dark areas). All islands of a certain technology are seen by the primary network as a *Hotspot Network* (HN) – a secondary network.

A user is connected to the GPRS network and can have other sessions simultaneously. Each HN supports the notion of a session (i.e. IEEE 802.11 has one, HiperLan has another, etc.). Differently from the other proposals is the fact that a session survives the disconnection periods when the user is moving in a dark area of a certain WLAN. For instance, the user began a 802.11 session at the airport, took a taxi to a hotel, and when he is in the hotel, the same session is still on using the WLAN infrastructure of the hotel (it is assumed that both have agreements with 3GPP operators). On the way from the airport to the hotel, if the user needs to be contacted in the context of that session the primary network is used.

Other works consider all RANs at the same level. (Tönjes, 2002) defines a flow router at the core that uses all RANs. This will lead to the existence of control functions in all of them. If only one is chosen to have these features the system will fall back to ours. Moreover, with a monolithic core it would be more difficult to add a new RAN.

## 4 ARCHITECTURE

Figure 1 shows the architecture for the data traffic

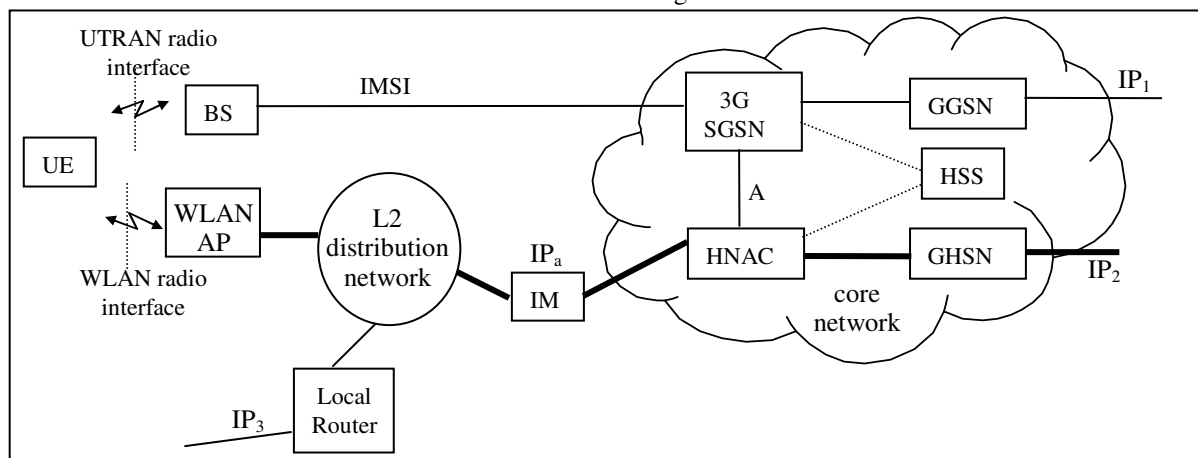

Figure 1 – Data traffic in the hybrid network

(no access control, billing, etc.). The new components are the HNAC (Hotspot Network Area Controller) which controls one (or more) island, and the GHSN (Gateway Hotspot network Support Node) which is responsible for context management and Internet access. The thicker lines belong to the core but they are not present in the current 3G core. All the high speed traffic goes through them not overloading the current 3G infrastructure.

The 3GPP specification for scenario 3 (3GPP, 2003) has a component that merges the HNAC and the GHSN, called PDG (Packet Data Gateway). The PDG is not connected to the SGSN (line A) as we propose and all data integration between the systems is done at IP level.

An UE has its identification at core level in the form of an IMSI (International Mobile Subscriber Identity) and the attachment procedure for GPRS is the standard one (with temporary identifiers). In the GPRS world an IP session can be established via the GGSN (PDP context), having a routable address, called IP<sub>1</sub>.

If the UE senses a WLAN to which it can perform a connection establishment, it does so. From that time on it can use the 'local router' to access the Internet directly. An IP<sub>3</sub> address is used for that path (whether this address is a care-of-address and whether the local routing is performed at level 3 or level 2 is irrelevant to this paper). If the WLAN has roaming agreements with a 3GPP operator the UE can perform an attachment procedure with the 3GPP operator (3GPP, 2003). The attachment defines a *local identifier* at core level for the UE in that WLAN (possibly with temporary addresses, too). In figure 1 an IP address was used as an example for the local identifier (IPa). From this time on an UE identified by the IMSI can be contacted via UTRAN using the IMSI, or via WLAN using the IPa. It is important to note that no assumption is made about an *all-IP* technology in our system. It is sufficient that it is *IP-enabled*. I.e. the UE communicates at IP level with the core, but the core forwards packets to the IM to be delivered to an UE with a specific local identifier. The core does not assume any delivery protocol in the island. The IM can use a layer 2 routing if it suits better. The important thing is that IPa is stable. If the UE wants to use the Internet via the WLAN it creates a PDP context (in similar modes as to the GPRS case) and a routable address IP<sub>2</sub> is defined at GHSN. Every time there is an attach update (in a different WLAN, for instance) a new IPa is chosen but IP<sub>2</sub> remains the same.

IP<sub>1</sub> is the main, fixed, UE address. IP<sub>2</sub> and IP<sub>3</sub> should be used on a temporary basis (e.g. client applications). Therefore, reuse of addresses can be made making the system scalable.

## 4.1 Overview of the Interactions

The HSS (Home Subscriber Server) has the operational information about the UEs. Besides the GPRS-related parameters that the HSS already has, there is the information if an UE is HN attached, has a session established and if it is currently inside a WLAN coverage area (and the identification of the HNAC responsible for it). SGSN and HNAC will go to HSS to get updated information. The HSS also provides authentication vectors, subscriber profiles, and charging information.

The communication between the core (SGSN and HNAC) and the UE can use any RAN. We will describe two approaches: the first one, the smooth transition, consists in keeping the GPRS almost as it is with little add-ons. Any PS traffic will use UTRAN but the HNAC can communicate directly with the UE via WLAN, or can relay the traffic through the SGSN to be delivered to the UE via UTRAN (using the interface link A in figure 1. A more concrete description is given below); the second approach is more abrupt – both SGSN and HNAC can convey their traffic through the other component if they see some advantage. Currently, a tunnel called GTP-U (GPRS Tunneling Protocol – for User Plan) is established between the GGSN and the serving RNC (Radio Network Controller). In our second approach the tunnel goes as far as the SGSN and a new tunnel is formed from there on. It is a return to the original GPRS specification. Figure 2 shows the protocol stack at an UE. There is a Connection Manager (CM) that manages the status of both connections and offers a unique interface to both RANs. The Delivery Service is a confirmed service and switches to the UTRAN if it senses a failure in the WLAN. If more than one RAN is

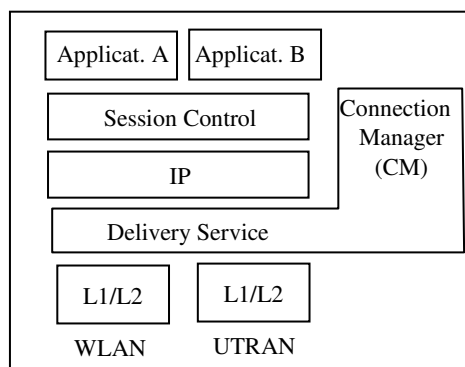

Figure 2 – Protocol stack at a UE

active the default one for each message is used. The CM can signal the applications (or be queried by them) about the current status of a specific connection. With this information, applications can

avoid using the link if the proper interface is not active (transferring only urgent information, for instance). The CM is able to contact each of the core network components (SGSN or HNAC) either directly or via the other RAN (for link maintenance messages, etc.). The Session Control is responsible for session survival when the UE is in dark areas.

For the smooth approach the following interactions are needed: (a) permission by the SGSN to create a session between the UE and the HNAC (using a PDP context just as the GGSN uses them, with the Session Management Protocol) (Kaarainen, 2001). A GTP-U tunnel is created between the HNAC and the UE (more precisely with the serving RNC); (b) an event service from the SGSN to notify relevant events – “UE availability”, “cell update”, “routing area update”, “positive cell identification” and “undefined cell identification”. It is important for session management by the HNAC; and (c) mobility management information by the SGSN (cell identification if in GPRS state *ready*, or routing area identification, otherwise) - it can be useful for the HNAC. Suppose HNAC has a relation between cells and WLAN islands topologies. It can force the WLAN interface to switch off if no islands are known in a certain routing area, for instance. It is also important because HNAC change of responsibility can happen when the UE performs a routing area update.

For the abrupt approach the current GTP-U tunnels have to be divided in two parts: one from the GGSN to the SGSN; and another from the SGSN to the RNC. The same will happen from GHSN to HNAC, and from HNAC to IM. This separation allows the second tunnels to be established either via the default RAN, or via the other RAN.

## 4.2 Scope of Integration

In our system there is no need for vertical handovers because the GPRS session is always on and the other RANs are used as a complement. Communication to the UE can use indistinguishably any available RAN. A total switch of the communication from one RAN to another is performed by the core components, so no information is ever lost. In systems with traditional vertical handoff, the dominant factor is the time the UE takes to discover that it has moved in/out of coverage (i.e. the cell has to become active or inactive) (Steem, 1998). Using RANs in a complementary form as we do, this time is not so critical, and the GPRS can provide a minimal bandwidth.

As the integration is performed at core level current services can work with secondary RANs in a

very easy way. Figure 3 (taken from (3GPP, 2003)) shows how 3GPP plans to support SMS over WLAN. A service specific gateway, IP-SM-GW, must exist and offer an interface similar to an MSC or an SGSN (interfaces E or Gd) to the GMSC/SMS-IW MSC. The address of this gateway is returned by the HSS in the “send routing information for short message”. This gateway has a private database to associate MSISDN to IP addresses. UEs in WLAN have to specifically register and specifically authenticate for SMS services and have secure associations to the gateway. The gateway communicates with the UE via Internet.

In our system (abrupt approach), the SMS service could be provided without any modification. The SGSN just gets the message and can use the HNAC to convey the message to the UE, using the secure associations that are already in place.

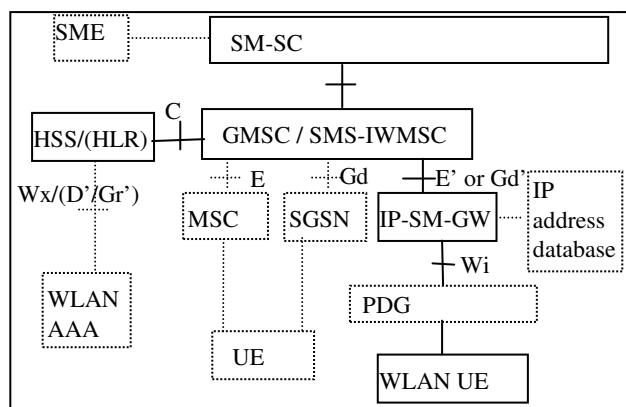

Figure 3 – Support of SMS over WLAN

## 4.3 Application support at core level

HNACs have already the task of maintaining sessions between appearances of the UE in WLAN islands. A step further is their ability to work with the applications in order to take advantage of the mobility (and connect times) of the UEs to perform the application task in a specific manner. This is not the traditional approach in the Telecom world and resembles more the activity of a middleware level managing mobility.

In the Telecom world networks are seen as closed systems that offer services. Services are carefully specified procedures that use lower level procedures called *bearer services*. The control procedures of the network are seldom accessible from the exterior and well protected from external components. It is interesting to see that the same approach is being planned for the introduction of Voice over IP (VoIP) services (Lin, 2002) on top of GPRS. The RAN and

the GPRS network together are called the *bearer network*. Through the *Gm interface* (which includes radio, Iu, Gn, and Gi), the *bearer network* provides bearers for signaling (control plane) and data (user plane) between the UE and the IP Multimedia Subsystem (IMS) (placed outside the core network). The *bearer network* nodes (RAN, SGSN, and GGSN) are not aware of the multimedia signaling between the UE and the IMS.

The typical way to add new functionalities and behaviors to networks is using frameworks such as Intelligent Networks, or in case of UMTS, the CAMEL (Customized Applications for Mobile network Enhanced Logic), (Kaarainen, 2001). However, the extensions are traditionally related with the basic services and with inter mobile-network interactions. For instance, personalization of services, different control over switched circuits, virtual home environments when roaming, etc.

In our system, HNACs can have a standard (and protected) programming interface to be used by third-party organizations to build services and applications that take advantage of the information gathered at the core (and not accessible today). The end of this paper has an example of one.

## 5 HN OPERATION

The interaction between an island and its controlling HNAC is performed by the *Island Manager* (IM). The IM provides a stable identifier for the UE and forwards packets between the UE and the HNAC. In terms of security the 3GPP network can offer an authentication service to the WLAN owner (WLAN connection establishment is not covered by the 3GPP specification, obviously). It is important that both networks rely very little on each other (not disclosing authentication vectors, for instance). Figure 4 shows the proposed setup. It

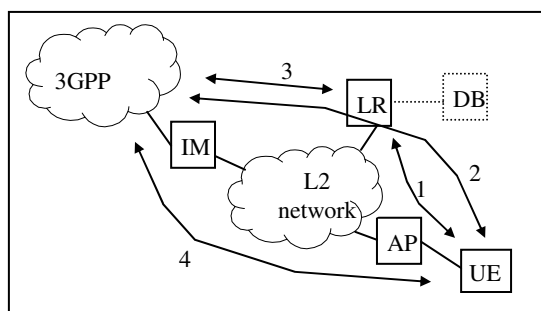

Figure 4 – Security flows for UEs

consists of two, almost similar, phases. The first provides WLAN authentication assisted by the 3GPP network, and the second provides 3GPP

authentication via WLAN. The UE senses a WLAN and creates a provisional secure association with the local router (LR) (1) (it is assumed that the AAA functionality is inside the LR). Using this association it sends a message to the LR to state its willingness to authenticate. The LR triggers an authentication process within the HNAC. The HNAC gets authorization vectors from the HSS and issues a challenge. The local router relays the challenge and the corresponding response between the HNAC and the UE (using, for instance EAP Response/Identity) (2). The result of the authentication is given to the LR by the HNAC (EAP-Success/EAP-Failure) (3). At this moment the LR knows the UE has the identity it claims it has. The LR checks if the UE can use the WLAN, by consulting a local database of users. If so, it creates a definitive secure association (in the scope of WLAN), provides the keying material to the UE for local WLAN use, and informs the address of the IM. The 3GPP could also approve a user not belonging to the local WLAN community, in which case the LR will tell the user that a local session cannot be established but the IM address is given for a WLAN-3GPP session.

If the UE has passed the first phase, it can now start an authentication process with the 3GPP to create a context there (4). The secure association is created with the 3GPP without intervention, or knowledge, of the WLAN. The attachment to the 3GPP network is covered in (3GPP, 2003) and uses the EAP authentication procedure, providing enough keying material for a secure tunnel to the PDG (or HNAC in our case) through the IM. Once attached, the HSS has the indication that the UE exists and a session can be established (both by the UE and by the 3GPP). A WLAN session can also be established using the UTRAN interface (particularly useful in dark areas). Each time a new island is entered a fast update procedure must be done.

The concrete mobility management protocol used inside the island and any mechanism to save power or bandwidth are irrelevant and should not be seen from the 3GPP. I.e., a micro-mobility move must not change the local (IPa) address to maintain the secure associations and the information in the core. Any possible paging mechanism prior to the delivery of a message is also hidden from the 3GPP. From the core level point of view a packet is simply delivered.

Figure 5 shows the state diagram of the interaction UE-3GPP. It is assumed that the UE is always attached to the GPRS. Its idle state is the *Disconnected* state – there is no operational WLAN information about the UE in the core.

When the UE attaches and creates a PDP context, the address  $IP_2$  is defined, and the HSS has information about its existence. An HNAC will be responsible for it and the state changes to *Registered*. In this state it is assumed that the UE is always reachable via  $IP_2$ .

Any communication to/from the UE is done in the context of a *session*. A session represents extra attention by the HNAC to the position of the UE (using also the mechanisms provided by the SGSN as stated above). The *Session* state is entered when either the UE or the HNAC issue a *Start of Session* message. The sub-state *Connected* means that the

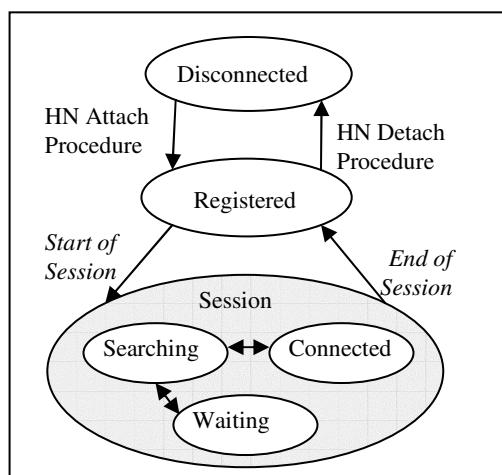

Figure 5 – UE-3GPP State Diagram

UE is inside an island. The sub-state *Searching* is entered when the UE is out of coverage. In the *Searching* sub-state, the HNAC forces the UE to be in active GPRS state to know its cell ID. It can happen that the UE is in a cell that has no islands nearby. In this case the HNAC can order the UE (via UTRAN) to go to sub-state *Waiting* to save battery power. When the UE moves to a cell where an island exist it is told to change again to *Searching* (note that these sub-states are simply optimizations and can exist, or not).

Depending on the application it can be easy to know when a session finishes, or not. If it is, an *End of Session* message is sent. If it is not, a watchdog mechanism based on inactivity triggers the sending of the message, for instance.

## 6 APPLICATION MODEL

Applications may interact with external networks using one of the three connections: UTRAN ( $IP_1$ ), WLAN direct ( $IP_3$ ) or WLAN-HN ( $IP_2$ ). The

application models for the first two follow the traditional Internet models – correspondent nodes communicate with fixed remote IP addresses and send data as soon as it is available. For the WLAN-HN we can have a different approach that optimizes the use of scattered hotspots over a ubiquitous 3GPP network. With proper support at the core network, these applications will be able to maintain sessions independently of the hotspot availability, and communicate the bulk part of the data only when the UE is in the *Connected* sub-state.

Application functionality is divided between the UE and the serving HNAC (figure 6). In the UE we have a *front-end component* implementing the user interface and interacting with the session control entity and the associated lower services (which behave as a middleware platform for the applications). In the serving HNAC we have the *back-end component* that cooperates with its peer on the UE and maintains a stable interface with external entities. By stable it is meant that any optimization use of the air interface is hidden from the external applications. These components work in the context of the  $IP_2$  session (Fig. 1), but can communicate with each other using the WLAN RAN or the UTRAN. They can work in an “*Always Connected*” mode, using the SGSN each time the UE is in an HN dark area, or, more interestingly, in “*Hotspot Connected*” mode, communicating only urgent information via SGSN while waiting for the UE to become *Connected* again.

The middleware performs session and mobility management providing applications with context information. The middleware layer gathers UE mobility information from the SGSN and network status from probing its network interfaces. These events are used by the middleware services to update the execution environment parameters. Using this information, applications are able to adapt their behavior to different network conditions and mobility scenarios.

For instance, if a user wants to download a news summary stored in a web site, both components start a new session, and the *back-end component* will start to fetch the videos. If the UE gets out of coverage the *back-end component* can store a portion of the data waiting for the UE to pop up. Later, when the UE enters into a hotspot, the information will be forwarded to the *front-end component*. In the meantime both modules can exchange control information via the SGSN/UTRAN. This pre-fetching feature optimizes UE connection time with HN, avoiding fetching delays from exterior networks. The back-end context has to be highly

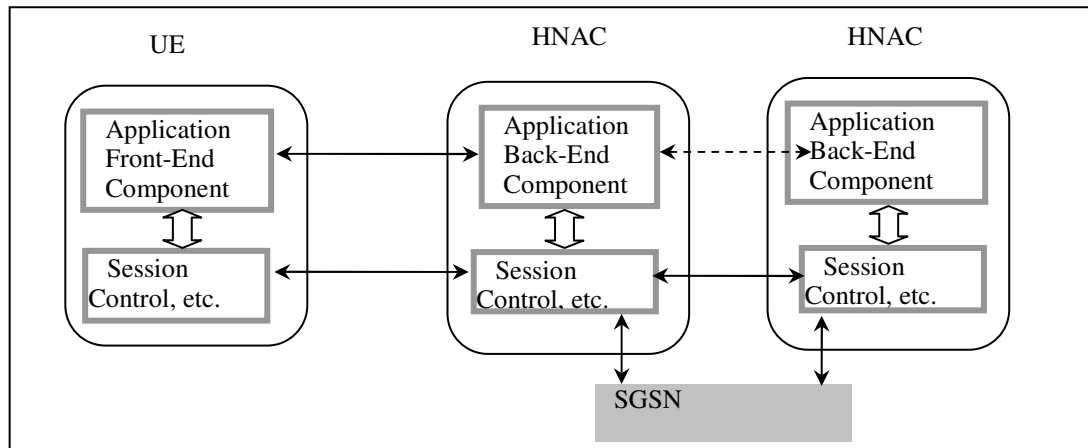

Figure 6: Functional Blocks for HN session applications

mobile because it might have to change to another HNAC pursuing the UE (dashed arrow in the figure). Information can be stored either in the HNAC or in a server close to the core network with a guaranteed delay for access (avoiding copying when the serving HNAC changes).

## 7 CONCLUSIONS

The internetworking of wireless infrastructures performed at core level with a pivot network seems a simple and executable model. First, as most of the control features already exist in the PLMN, they can be absent in other networks. Second, because certain details on secondary networks (such as micro-mobility) are not managed at core level, because it defines an environment where new features and services can be added to the core.

The addition of new modules at core level with standard (and protected) programming interfaces can open up new possibilities to explore terminal mobility (a topic that is absent today).

Our solution does not impose relevant requirements to the overall system: the architecture does not need to be all-IP; there is no critical dependence on vertical handovers; and, does not create extra load to the current 3GPP core network.

Topics that are relevant for further work include the algorithms to be used on top of the HNACs to explore the mobility of UEs and their connection periods, and the viability of service continuity using this type of handovers.

## REFERENCES

- 3GPP, 2003. Group Services and System Aspects; 3GPP system to WLAN internetworking; System Description (Release 6), TS 23.234.v.2.3.0, Nov.
- Frenkiel, R., et al, 2000. The Infostations Challenge: Balancing Cost and Ubiquity in Delivering Wireless Data, *IEEE Personal Communications*, v.7, pp66-71, n.2, April.
- Frodigh, M., et al, 2001. Future-Generation Wireless Networks, *IEEE Personal Communications*, v.8, pp 10-17, October.
- Salkintzis, A., et al., 2002. WLAN-GPRS Integration for Next-Generation Mobile Data Networks, *IEEE Wireless Communication*, v.9, pp 112-124, October.
- Buddhikot, M., et al., 2003. Design and Implementation of a WLAN/CDMA2000 Interworking Architecture, *IEEE Comm. Mag.*, pp 90-100, November.
- 3GPP, 2002. Group Services and System Aspects; Feasibility study on 3GPP system to WLAN internetworking; (Release 6), TS 22.934.v.6.1.0, Dec.
- Wu, G., 2002. MIRAI Architecture for Heterogeneous Network, *IEEE Comm. Mag.*, pp 126-134, February.
- Tönjes, R., 2002. Flow-control for multi-access systems, *PIMRC'02*, pp 535-539, September.
- Steem, M., Katz, R., 1998. Vertical Handoffs in wireless overlay networks, *Mobile Networks and Applications*, v.3, pp 335-350.
- Lin, Y., et al., 2002. An All-IP Approach for UMTS Third-Generation Mobile Networks, *IEEE Network*, v.16, n.5, pp 8-19 September/October